



Industrial Breeze **Plate Heat Exchanger**

Operating &
Maintenance Manual

VERY IMPORTANT - PLEASE READ CAREFULLY

Running	1	Page 1
Safety Points	1.1	Page 1
Start Up	1.2	Page 1
Working Principles	1.3	Page 2
Installing	2	Page 3
Sizing and Selection	2.1	Page 3
Installation	2.2	Page 6
Operation and Set Up	2.3	Page 7
Health	3	Page 15
Maintenance	3.1	Page 15
Service	3.2	Page 15
Spares	3.3	Page 15
Information	4	Page 16
Specification	4.1	Page 16

1. Running

1.1 Safety Points

- During operation, the unit may have very hot or cold surfaces.
- The temperature probe is installed directly in the secondary flow. Don't remove when the system is hot, full or under pressure.
- The equipment has danger from electricity. Do not remove covers or allow any exposed live parts. Isolate before working on the unit.
- Take care when lifting. Only use the designated lifting point. Use only certified lifting equipment capable of lifting the weight. Water may also be present and spillage could occur.
- Never lift the HT breeze by any associated pipework or pipe connections.
- Take care when handling, as some of the edges may be sharp.
- Electrical and Mechanical functionality must be considered prior to connecting any none factory fitted equipment. E.g. Pumps, Valves / Actuators etc

Switch on via switch ⁽¹⁶⁾

The front panel will illuminate. After a few seconds of self checks, the displays will settle to the Day ⁽¹⁾ (Time-clock only), Time ⁽²⁾ and Temperature ⁽³⁾. The pumps will start ⁽¹¹⁾ and the valve will open ⁽¹⁵⁾ and the system healthy indicator ⁽¹³⁾ will illuminate.

In the majority of applications, the resulting control and running will be satisfactory. The standard temperature setting is 60°C and the unit will run continuously. (24 hour operation).

To change any of the default settings, see section (2.3).

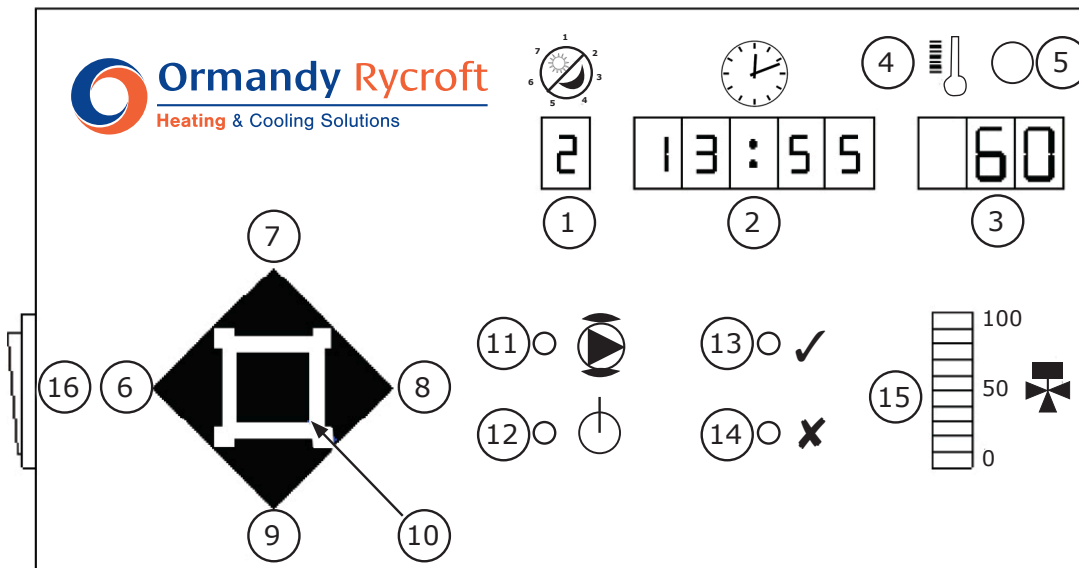

- | | | |
|------------------------------------|------------------------------|-------------------------------|
| 1 Day/Mode Display | 7 Value Increase Push Button | 13 System Healthy Indicator |
| 2 Time/Alarm Display | 8 Step Right Push Button | 14 System Fault Indicator |
| 3 Temperature/Parameter Display | 9 Value Decrease Push Button | 15 Valve Position Bar Display |
| 4 High Temperature Alarm Indicator | 10 Mode Select Push button | 16 On/Off switch |
| 5 Reset Push Button | 11 Pump Energised Indicator | |
| 6 Step Left Push Button | 12 Power On Indicator | |

1.2 Start Up - Checks

Checks	Complete (✓)
Check that electrical installation is complete.	
Check that the mechanical installation is complete.	
Check that the system has been flushed and that there are no leaks.	
Check that any air has been eliminated from the system.	
Check that valves are opened in the required sequence.	

1. Running

1.3 Working Principles

The HT Breeze comprises of a Supapac Plate Heat exchanger, either with a 3 port or 4 port control valve, primary pump, temperature sensor and PID controller, all mounted on a skid base.

The motorised 3 or 4 port control valve, allows rapid adjustment of the primary heat input to match changes in secondary hot water demand.

The HT Breeze requires no insulation and the design ensures that the outlet temperature does not fall below the set point (60°C default, but can be adjusted to suit customer requirements) and consequently reduces the risk of legionnaires disease.

Providing the class of accommodation and details of the number and type of fixtures are known, Ormandy Rycroft will be pleased to recommend the optimum size of HT Breeze.

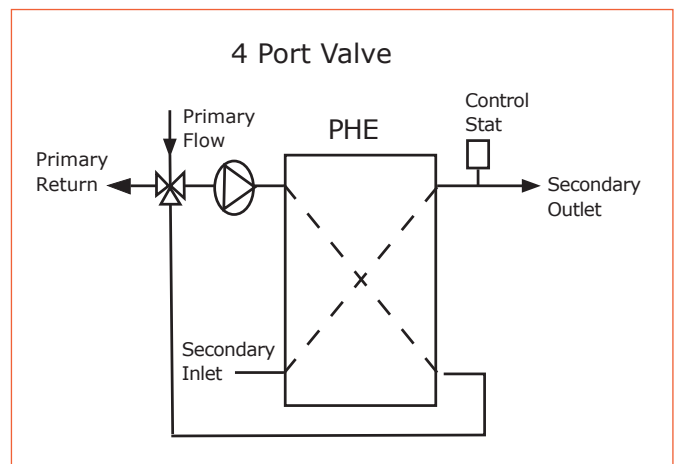
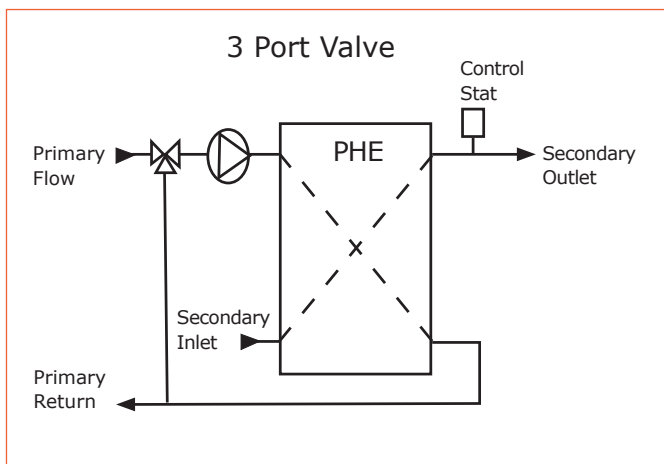

With buffer vessel to form a semi-instantaneous water heater

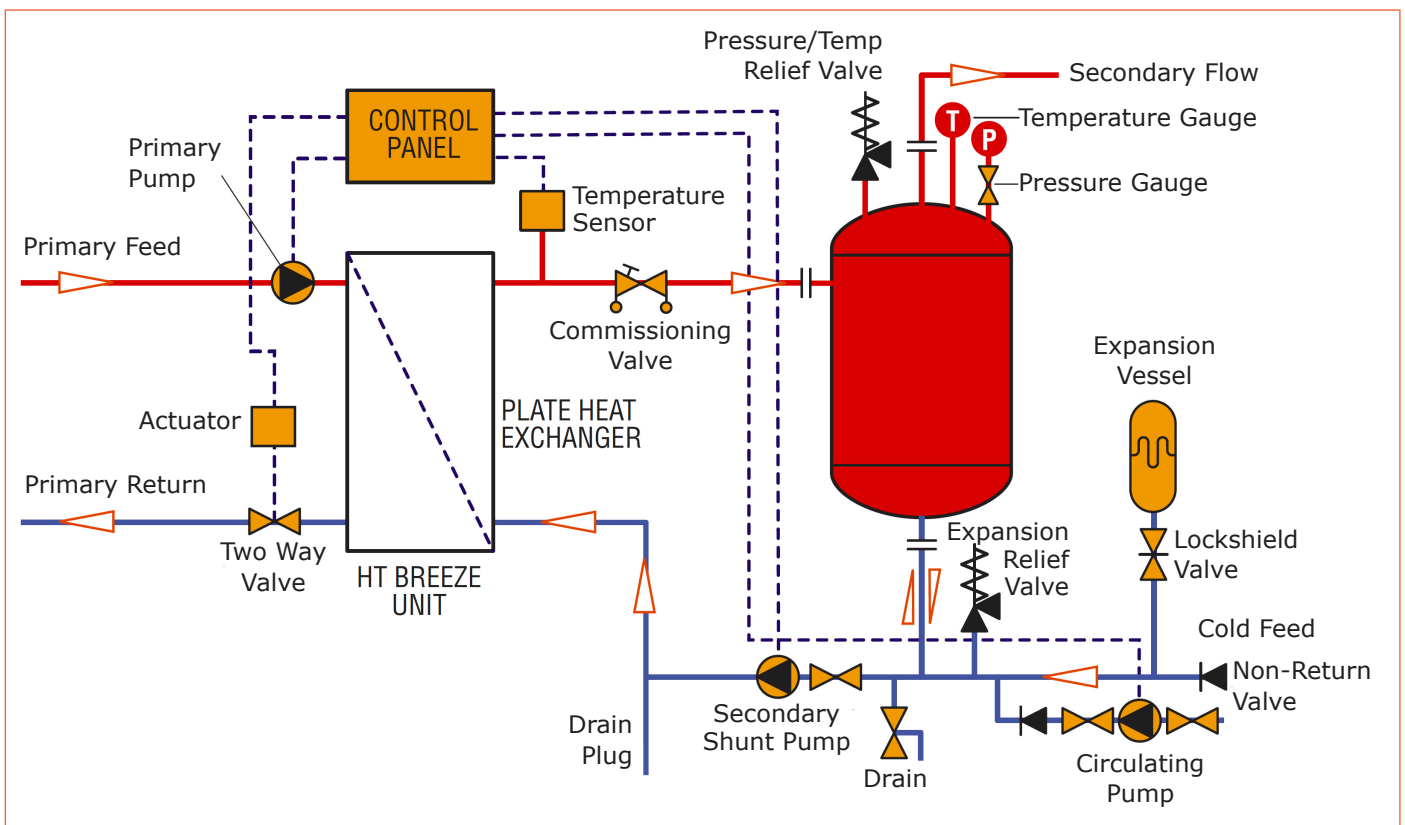

2. Installing

2.1 Sizing and Selection

To size a stand alone HT Breeze, use the following demand factors.

Table 1

Facility	Private Hand Basin	Public Hand Basin	Shower	Bath	Slop Sink	Bar Sink	Kitchen Sink	Washing Machine	Lab Sink	Dish Washer
Hospital	1	2	4	4	4		10	10	3	10
Hotel & Residential Hall	1	2	4	4	4	12	10	10		10
School	0.5	3	10	-	3		10	3	3	10
Sports Centre/ Barracks	0.5	2	10	-	3	12	10	-	-	10
Restaurant	0.5	4	-	-	12	12	19	-	-	10
University	0.5	3	10	-	3	-	10	-	3	10
Offices	0.5	3	3	-	3	-	10	-	3	10
Factory	0.5	3	4	-	3	-	10	-	3	10
Apartments	1	-	4	4	3	-	3	3	-	2

Sizing Considerations

Careful consideration must be given to the sizing of stand alone instantaneous water heaters. Standard demand units incorporate a degree of diversification, that would be inappropriate for continuous use applications.

A more desirable method of sizing for continuous applications is to complete a fixture count and allocate an appropriate flow for each fitting. It should also be noted that shower demands for Schools, Sports Centres and Universities should only be used for medium to large installations. Please refer to our design department for further information.

Example

From Table 1. A 173 bed Hospital ward with showers, hand basins and sinks

42 single person showers	42 x 4	= 168	The shower factors are based upon intermittent use.
55 private hand basins	55 x 1	= 55	
9 public hand basins	9 x 2	= 18	Where certain activities may result in all showers operating together, please contact our sales department for advice.
3 slop sinks	3 x 4	= 12	
15 baths	15 x 4	= 60	
Total Demand Units		= 313	

2. Installing cont

2.1 Sizing and Selection cont

The correctly sized HT Breeze can now be selected from Table 2

Table 2

HT Breeze Model	Maximum Demand Units	Max Continuous Duty @ 60°C (litres/sec)	Boiler Power (kw)	Min Secondary Volume (litres)
CP-B25	15	0.25	52	45
CP-B50	23	0.50	105	75
CP-B75	45	0.75	157	85
CP-B100	70	1.00	209	125
CP-B125	90	1.25	261	135
CP-B150	130	1.50	313	150
CP-B200	210	2.00	418	200
CP-B250	320	2.50	522	250
CP-B300	480	3.00	627	300
CP-B350	640	3.50	732	350
CP-B400	820	4.00	836	400
CP-B450	1050	4.50	935	450
CP-B500	1300	5.00	1040	500

These sizes represent the standard range of HT Breeze instantaneous water heaters.

For larger requirements for both single and three phase, please contact our technical department.

Both Standard and Special designs can be offered to suit your specific requirements.

2. Installing cont

2.1 Sizing and Selection cont

To size a HT Breeze and Buffer Vessel, use the following maximum demand rates.

Table 3

Facility	Private Hand Basin	Public Hand Basin	Shower	Bath	Slop Sink	Bar Sink	Kitchen Sink	Washing Machine	Lab Sink	Dish Washer	Load Factor
Hospital	10	15	70	60	50		80	100	40	150	0.7
Hotel & Residential Hall	10	15	50	50	50	100	80	100		150	0.5
School	5	20	180		40		80	40	40	150	0.8
Sports Centre /Barracks	5	15	220		40	100	80			100	1
Restaurant	5	25			100	100	140			150	1
University	5	20	220		40		80		40	150	0.8
Offices	5	10	180		40		40		40	100	1
Factory	5	20	120		50		80		40	100	1
Apartments	5		50	50	40		20	40		20	0.7

Example

42 single person showers	42 x 70	= 2940
55 private hand basins	55 x 10	= 550
9 public hand basins	9 x 15	= 135
3 slop sinks	3 x 50	= 150
15 baths	15 x 60	= 900

Total Volume = 4675

Load Factor from Table 3 = 0.7

Total Demand Rate = 4675 x 0.7 = 3273 litres/hr

The HT Breeze and Buffer Vessel combination should be sized as follows:-

The Buffer Vessel Capacity = 25% of the total hourly demand, therefore the required storage capacity = 3273 x 0.25 = 818 litres. The nearest standard Buffer Vessel sizes are 800 and 900 litres. It is recommended to go up in size and therefore a 900 litre Buffer Vessel should be selected.

The VariEplate can be selected as follows:-

Continuous hourly demand	= 3273 litres
Specific Heat Capacity of Water	= 4.187 kJ/kg, °C
Cold Feed Temperature	= 10°C
Secondary Flow Temperature	= 60°C

Therefore the required kw rating = $\frac{3273 \times 4.187 \times (60-10)}{3600}$ = **190.3 kw**

The nearest standard HT Breeze is a CP-B100 which is rated at 209 kw

2. Installing cont

2.1 Sizing and Selection cont

A HT Breeze and Buffer Vessel combination is used when water demand is not constant, but high flow frequently occurs. Boiler power requirements are reduced by storing hot water in the buffer vessel for peak demands.

The HT Breeze should always be installed with a secondary return line coming back from the system and into the cold feed line prior to the HT Breeze or Buffer Vessel. This will remove nuisance high limit tripping, due to temperature overshoot, which would occur if the unit was installed on a 'dead end' system, when an outlet was closed. To ensure full heat dissipation, the secondary volume should not be less than that shown in Table 2.

For larger capacities contact the sales department for advice.

2.2 Installation

Foundations

The HT Breeze should be mounted on prepared and level foundations.

Lifting

One lifting hole is provided on the top of the VariEplate control panel. Avoid the use of chains as screwed connections may be damaged by the links.

Caution: Never lift the HT Breeze by its pipework or pipe connections.

Pipework

Make sure that the pipework flanges are square and correctly spaced before bolting up. See that the weight of the pipework is taken by external supports and not by the VariEplate. Allowances should be made for expansion of the pipes, either by suitable bends or flexible joints. Tighten flange bolts in a diametrically opposite sequence, not consecutively round each flange.

Connections

Threaded connection may be sealed with PTFE tape. Flanged connections should be sealed with a suitable gasket and sealing agent.

Liquid Expansion

Changes in volume with temperature must not be overlooked. The system pressure will rise dramatically if there is nowhere for water to expand. It is not advisable to use a relief valve as a means of releasing the excess water.

Vented systems use the atmospheric vent as an expansion pipe, with discharge back into the tank. Unvented systems require a separate expansion tank.

Venting

Vent valves must be fitted at the highest point in the connecting pipework, so that the VariEplate can be bled of air for initial operation. It is **essential** that the flooded can type pump motors which are commonly used for all HT Breeze pumps are bled of air and flooded before starting. See the pump manufacturer's instructions.

Filling

Before filling the system, check that the drain valve is closed and all air vents are open.

Flush out the system before installing the HT Breeze to remove any foreign matter. Close any manual air vents and run the HT Breeze.

Crack the vents to release air

Caution: Do not fill the system too quickly, otherwise pockets of air may become trapped.

2. Installing cont

2.3 Operation and Set Up

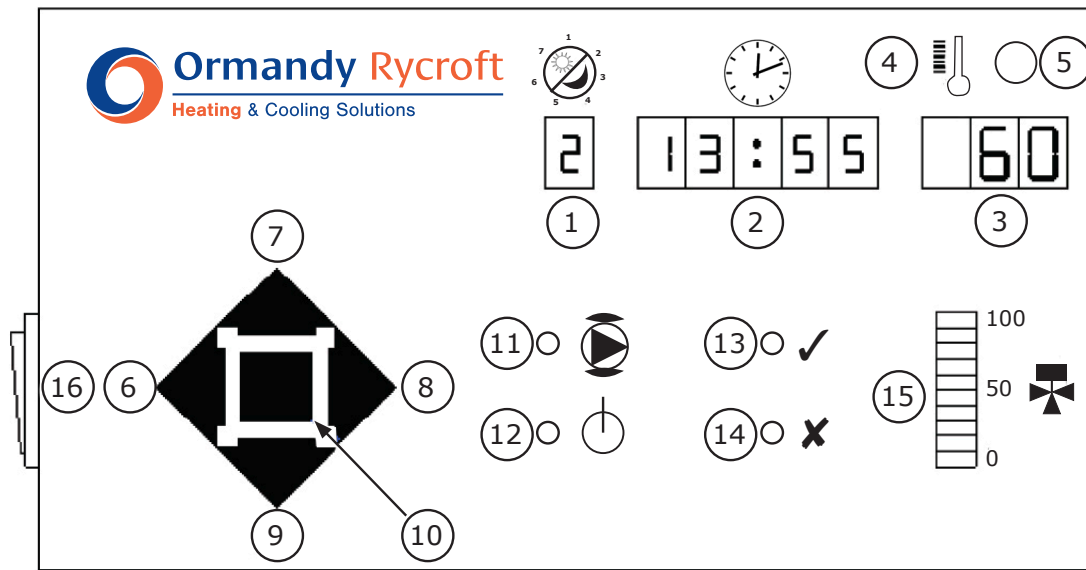

- | | | |
|------------------------------------|------------------------------|-------------------------------|
| 1 Day/Mode Display | 7 Value Increase Push Button | 13 System Healthy Indicator |
| 2 Time/Alarm Display | 8 Step Right Push Button | 14 System Fault Indicator |
| 3 Temperature/Parameter Display | 9 Value Decrease Push Button | 15 Valve Position Bar Display |
| 4 High Temperature Alarm Indicator | 10 Mode Select Push button | 16 On/Off switch |
| 5 Reset Push Button | 11 Pump Energised Indicator | |
| 6 Step Left Push Button | 12 Power On Indicator | |

Electrical Connections

Terminal Block

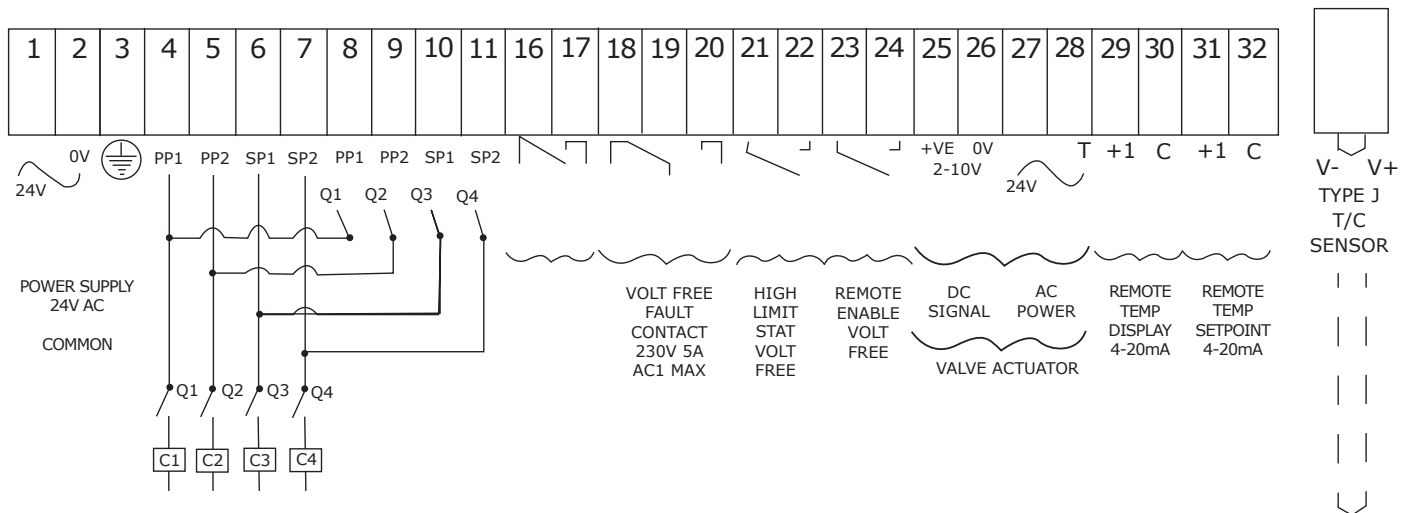

The Electrical connections are located in the terminal compartment. A description of the terminals can be found on the inside of the terminal compartment cover.

Connect a single phase 230V 50Hz supply to the Mains Input terminals. Max Full Load Current is 16A with the majority of units being considerably less.

If the unit is to be controlled remotely, connect the remote control switch or contacts to the **Remote enable** terminals. If the unit is to be controlled locally, fit a link between these terminals.

Do NOT apply voltage to the terminals of these contacts!

Voltage free fault relay contacts are provided for Remote Fault Indication.

2. Installing cont

2.3 Operation and Set Up continued

Operation

The HT Breeze is a self-contained unit, which controls up to two primary and two secondary pumps together with a 3 or 4-port valve to provide hot water. When the system is fitted with two primary pumps, they are operated on a shared duty-standby cycle with automatic changeover on pump failure.

The HT Breeze can be energised by its own internal time clock function, by a remote switch or Building Management System or by a combination of the two.

a) Remote Switch or Building Management System Control

The HT Breeze will be turned on when contacts connected to the **Remote Enable terminals** are closed. This allows the user to control the time of day when hot water will be available.

When the contacts are open the system is turned off.

b) Internal Time Clock Control

For this function to work the Time clock function should be turned on (see Set Up) and the **Remote Enable terminals** should be linked.

Under Time clock control, the HT Breeze will be turned on and off at preset times of the day. Up to two on and two off times can be programmed for each day of the week.

The system can be re-activated after it has automatically switched off, by pressing the **Value Increase ⁽⁷⁾** push button. Each press of this push button will add 30-minute increments to a total, which is shown in the Time/Alarm window. Pressing the **Value Decrease ⁽⁹⁾** push button will subtract 30-minute increments from the total time.

The time value counts down and when the time shown has elapsed, the unit will revert to normal time clock operation.

c) Remote Switch and Internal Time Clock Control

For this function to work the Time clock function should be turned on (see Set Up) and a remote Control switch should be connected to the **Remote Enable terminals**.

Under Time clock control, the HT Breeze will be automatically turned on and off at preset times of the day. Up to two on and two off times can be programmed for each day of the week. When contacts connected to the **Remote Enable terminals** are opened the HT Breeze will be turned off.

When the system has turned off under time clock control, it can be re-activated by pressing the **Value Increase ⁽⁷⁾** push button. Each press of this push button will add 30-minute increments to a total, which is shown in the Time/Alarm window. Pressing the **Value Decrease ⁽⁹⁾** push button will subtract 30-minute increments from the total time.

The time value counts down and when the time shown has elapsed, the unit will switch off and revert to normal time clock operation. However, when the system has been turned off under remote control, it cannot be re-activated by pressing the **Value Increase ⁽⁷⁾** push button.

2. Installing cont

2.3 Operation and Set Up continued

Set Up

The HT Breeze control unit is factory programmed with temperature and control settings that will suit most applications. However, we would recommend that the unit is commissioned to ensure correct operation and maximum efficiency. Contact our Service Department for details.

All the values are adjustable so that you can customise the unit to exactly match your system.

The set up routine is entered by pressing and holding the **Mode** ⁽¹⁰⁾ push button for three seconds. Press the **Step Right** ⁽⁸⁾ and **Step left** ⁽⁶⁾ push buttons to move forwards and backwards through the sequence. Press the **Value Increase** ⁽⁷⁾ or **Value Decrease** ⁽⁹⁾ push buttons to alter the value shown in the display. Press and hold the **Mode** ⁽¹⁰⁾ push button for 3 seconds to exit the set up routine.

Figure 1 - Set Up Sequence

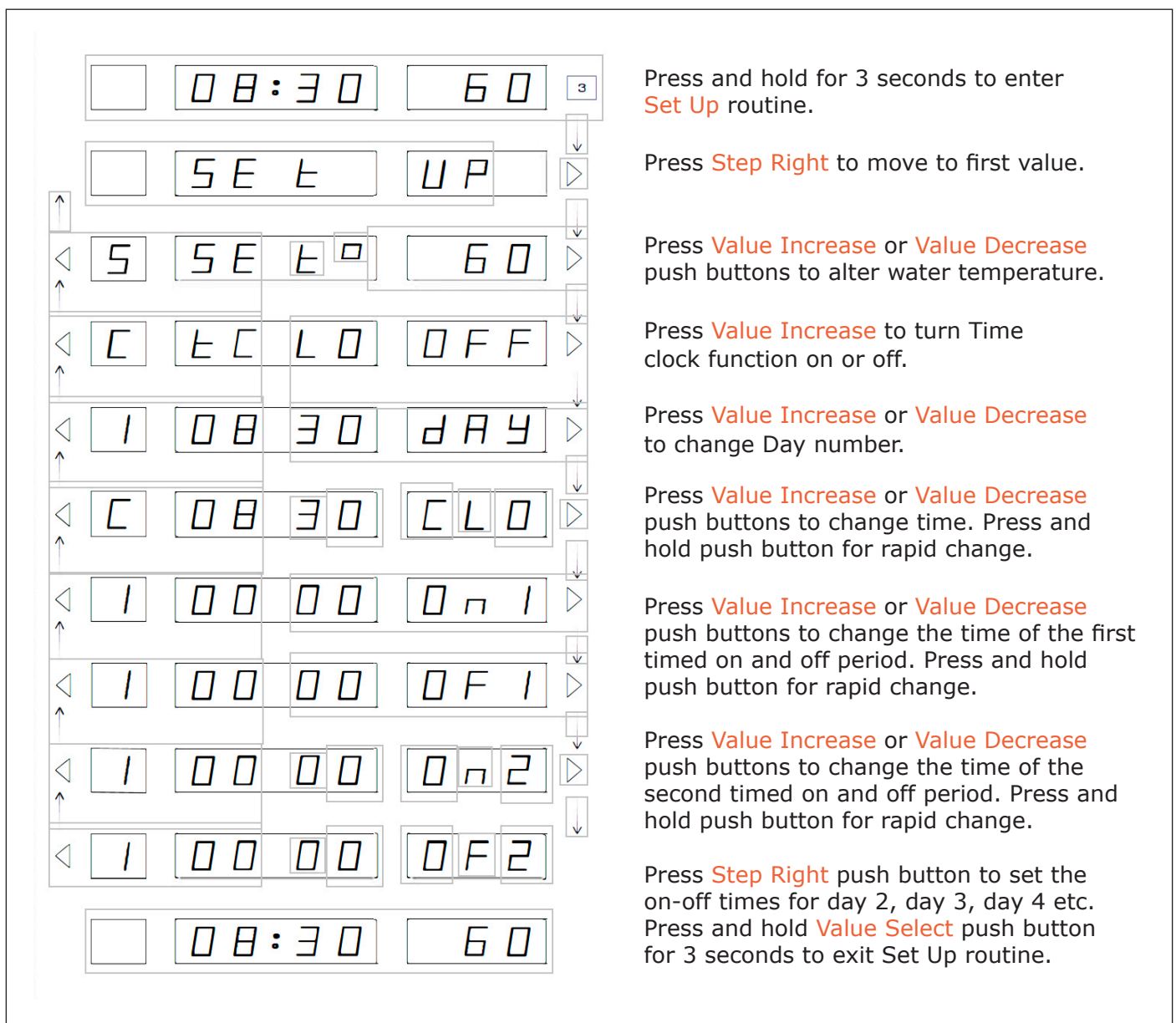

The system continues to control when the controller is in the set up routine, allowing adjustments to be made on the fly.

2. Installing cont

2.3 Operation and Set Up continued

System Faults

When a fault situation is detected, the System Fault (14) indicator will be lit and the internal Fault relay will be energised. The normal time and temperature display will be replaced by an alarm message. The messages and meanings are shown in Figure 2 below. If a system fault occurs when the controller is in the set up routine, the System Fault (14) indicator will be lit but the display will not be replaced by an alarm message. The alarm message can be viewed by leaving the Set Up routine.

Figure 2 - Alarm Messages

A	HL 1	77	First High temperature level detected.
A	HL 2	83	Second High temperature level detected - buzzer sounds and the system is automatically shut down.
A	LL	47	Low temperature detected.
A	PP 1F	60	Primary Pump No 1 failure - if two primary pumps are fitted, Primary Pump No 2 will be energised.
A	PP 2F	60	Primary Pump No 2 failure - Primary Pump No 1 will be energised.
A	SP 1F	60	Secondary Pump No 1 (shunt) failure - system is automatically shut down.
A	SP 2F	60	Secondary Pump No 2 (re-circulation) failure -system is automatically shut down.
A	TC F	- - -	Thermo-couple failure - the system is automatically shut down.
A	rd	60	System has been remotely disabled

The Second High temperature level alarm will automatically shut the system down and sound a warning buzzer. The buzzer can be silenced by pressing the **Reset (5)** push button. When the fault has been diagnosed and corrected, the system can be re-activated by pressing the **Reset (5)** push button again. This can only be performed when the temperatures have returned to near normal. All the other alarms will automatically reset when the problem has been corrected. Alarms constantly re-occurring could indicate that the system is incorrectly configured.

Advanced Set Up Routine

The system is supplied with default settings, which suit most applications. The advanced set up feature allows Installers and Engineers to tailor the settings to suit particular installations. The system continues to control when the controller is in the advanced set up routine, so that the results of adjustments can be seen immediately. In addition, manual control of the valve position is available.

2. Installing cont

2.3 Operation and Set Up continued

The set up routine is entered by simultaneously pressing and holding the **Mode** ⁽¹⁰⁾, **Step Left** ⁽⁶⁾ and **Value Decrease** ⁽⁹⁾, Push buttons for three seconds. Press the **Step Right** ⁽⁸⁾ and **Step Left** ⁽⁶⁾ push buttons to move forwards and backwards through the sequence. Press the **Value Increase** ⁽⁷⁾ or **Value Decrease** ⁽⁹⁾ push buttons to alter the value shown in the display. Press and hold the **Mode** ⁽¹⁰⁾ push button for 3 seconds to exit the set up routine.

Figure 3 - Advanced Set Up



2. Installing cont

2.3 Operation and Set Up continued

Night Set Back / Pasteurisation

When the DIP switch (5) for Night set-back/Pasteurisation is set to the on position and the unit is put into standby. When the set back/pasteurisation value (S SB TO) is set to above the normal set temperature (S SET TO), the controller will assume pasteurisation and will raise the temperature to the set back/pasteurisation value for one hour, before returning to standby. Alternatively, when the set back/pasteurisation value is set to below the normal set value, the controller will assume set back and will lower the temperature to this value until the normal day running begins.

Manual Control

The Advanced Set Up routine allows the engineer to position the control valve manually. This feature is active while this set up window is visible. This feature can be disabled and control restored to automatic by pressing the **Step Left** ⁽⁶⁾, or **Step Right** ⁽⁸⁾ push buttons to display another parameter or pressing and holding the **Mode** ⁽¹⁰⁾, push button to exit the advanced set up routine.

Remote Set Point Adjustment

When a 4 - 20mA signal is connected to the remote input, the set point can be varied between 20 deg c = 4mA and 100 deg c = 20mA at the rate of 5 degrees per milliamp.

It should be noted that BMS control of the unit starts as soon as the external signal of above 2mA is detected. Conversely, if the controller loses signal or the signal drops below 2mA, it will revert back to its own internal set point.

DIP Switch Settings

The physical configuration of the system and the Night Set-back function are programmed into the controller by setting the position of eight switches. The switches are located on the display printed circuit board. To change the position of these switches:

- 1) Isolate the mains supply to the controller.
- 2) Open the hinged door.
- 3) Remove the four black fixing screws and slide the control facia out of the enclosure, taking care not to pull the connecting cable.
- 4) Turn the facia over. DIP switches are located on the bottom edge of the circuit board.
- 5) Change the switch positions as required (see table below).
- 6) Replace facia, close hinged door and switch on the mains supply.

The following table shows the switch controls. (**Bold** positions are factory default values).

1	2	3	4	5	6	7	8	Function
On								No Operation
Off								No Operation
	On							No Operation
	Off							No Operation
		On						Fault Relay Operates During Remote Disable
		Off						Fault Relay, No Operation During Remote Disable
			On					Valve Output 2-10V
			Off					Valve Output 0-10V
				Off				Night Setback OFF
				On				Night Setback ON
					Off	Off		No Secondary Pumps Fitted
					Off	On		1 Secondary Pump Fitted (SHUNT)
					On	Off		1 Secondary Pump Fitted (RECIRC)
							Off	1 Primary Pump Fitted
							On	2 Primary Pumps Fitted

2. Installing cont

2.3 Operation and Set Up continued

Factory Default Settings

Set Up:

Alternative setting record (Date)	
Set Point	= 60
Time Clock	= Off
Day (Set)	= 1 = Mon 7 = Sunday			
Clock (Set)	= Time			
Day 1 ON 1	= 0000
Day 1 OFF 1	= 0000
Day 1 ON 2	= 0000
Day 1 OFF 2	= 0000
Day 2 ON 1	= 0000
Day 2 OFF 1	= 0000
Day 2 ON 2	= 0000
Day 2 OFF 2	= 0000
Day 3 ON 1	= 0000
Day 3 OFF 1	= 0000
Day 3 ON 2	= 0000
Day 3 OFF 2	= 0000
Day 4 ON 1	= 0000
Day 4 OFF 1	= 0000
Day 4 ON 2	= 0000
Day 4 OFF 2	= 0000
Day 5 ON 1	= 0000
Day 5 OFF 1	= 0000
Day 5 ON 2	= 0000
Day 5 OFF 2	= 0000
Day 6 ON 1	= 0000
Day 6 OFF 1	= 0000
Day 6 ON 2	= 0000
Day 6 OFF 2	= 0000
Day 7 ON 1	= 0000
Day 7 OFF 1	= 0000
Day 7 ON 2	= 0000
Day 7 OFF 2	= 0000

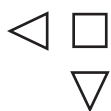

Set Set:

		Alternative setting record (Date)
Proportional Band	= 60%
Integral Time	= 4 mins
Derivative Time	= Off
High Limit	= 780C
Low Temperature Warning	= 350C
High Temperature Limit Time Delay	= 1 min
Low Temperature Limit Time Delay	= 1 min
Manual Valve Operation	= 00%		(Not presetting)		

2. Installing cont

2.3 Operation and Set Up continued

Primary Pump Overrun Time	= 5 mins
Primary Pump Overrun Temperature	= 400C
Secondary Pump Overrun Time	= 5 mins
Secondary Pump Overrun Temperature	= 400C
Night Set-back/Pasteurisation Temperature	= 680C
Primary Pump Duty Changeover Time	= 9 hrs

By pressing the **reset** ⁽⁵⁾ and **mode** ⁽¹⁰⁾ buttons simultaneously for a few seconds, the time clock settings will be returned to the factory default settings.

By pressing the **reset** ⁽⁵⁾ and **decrease** ⁽⁹⁾ buttons, the control and alarm parameters will be returned to the factory default settings.

3. Health

3.1 Maintenance

Where possible, a detailed inspection of the HT Breeze should be made after the first six months. This will provide an insight into future requirements for efficient maintenance. If the VariEplate is cleaned and there is no sign of corrosion, it can be safely assumed an annual inspection will be sufficient for future servicing. All electrical connections should be checked and tightened if necessary.

Caution:- Maintenance should only be performed by qualified personnel only. Electrical work should be carried out by a qualified electrician in strict conformance to the latest requirements.

In order to maintain the HT Breeze unit, you will require as a minimum the following tool kit:

- Set of Metric allen Keys up to M16
- Set of Metric spanners
- Set of Screwdrivers
- A pipe wrench to suit a maximum 50mm nominal pipe size.
- M16 friction ratchet and M16 deep ring spanner (CP-B25 to CP-B250)

Controller

The controller is run via an EPROM, that stores all the changes to the time programmes and other data. After the first six months, all connections in the panel should be checked and tightened if necessary.

Temperature Thermocouple

Ensure that the Thermocouple connections are satisfactory. Refer to the manufacturer's instructions.

Control Valve and Actuator

Check that the valve will open and close by using the manual facility on the controller. Electrical connection should be checked at the actuator. The linkage should also be tightened to ensure good mechanical contact. Refer to the manufacturer's instructions.

Hi-Limit Valve and Actuator (if fitted)

Check that the valve opens and closes by turning the power on and off . Electrical connection should be checked at the actuator. The linkage should also be tightened to ensure good mechanical contact. Refer to the manufacturer's instructions.

Primary Pump

Ensure that the pump is on the correct speed setting and that wiring is secure at all terminals.

Plate Heat Exchanger

A series of contoured plates with ports, form a plate pack with flow channels. The hot water flows down alternate channels, while the cold water flows up alternate channels. This creates 100% counter flow.

3.2 Service

Ormandy offers a full and comprehensive range of service and support. This encompasses the maintenance, commissioning and repair of general water heating equipment, including heat exchangers, boilers, pressurisation units, booster sets and calorifiers.

Contact our Sales Department - sales@ormandygroup.com

3.3 Spares

All HT Breeze component parts are available as replacement/spare items. Each unit carries a unique serial number (12345/6) and should be quoted when ordering spares.

4. Information

4.1 Specification

Power Supply Requirements

Voltage: 230/400vac, 50Hz.

Nominal current: Maximum 16Amps (Pump and Duty dependant).

Inputs

Temperature probe: Type J thermocouple (Grounded) via a 12 bit A/D converter (minimum 0.1 °C resolution). Display range: 0 - 250°C

Volt Free Contacts

To enable from remote source (Time-clock, SCADA,BMS, boiler controls etc) For connection of a supplementary high limit contact or thermostat as a second alarm Pump(s) fault contact.

Signal

4-20mA remote set point adjustment. 4mA = 20°C. 20mA = 100°C

Outputs

- Pumps (Power)
- Two primary (1 Duty, 1 Standby) single phase 230v 5A Maximum (Resistive load).
- Two secondary pumps (1 circulation, 1 shunt) single phase 230v 5A Maximum (Resistive load).
- Hi-Limit and Control actuator supply, 24 v.a.c 50 VA Max. Combined.
- Control signal 2 - 10v, 0 - 10.d.c 0. 1mA, Max.
- The effective control setting range 0 - 87°C

Volt Free Contacts

Changeover fault contact for remote alarm on fault, to SCADA, BMS, Annunciator etc.

Low temperature - contact closes on low temperature to allow a 'boost' of Primary heating.

For example/primary pump(s) start.

Signal

4 - 20mA remote indication of process variable. 4mA = 0° C.20mA = 100°C

Enclosure

The HT Breeze Circuit boards are fitted within a painted IP55 custom built, steel enclosure. It comes with door interlocked isolator and also houses all the other control equipment required to operate the larger capacity pumps. Entry is via a standard Double-bit key supplied with the unit.

***NOTE: The volt free contact terminals must not have voltage applied to them**



Duncombe Road,
Bradford, England BD8 9TB.

Telephone: +44 (0) 1274 490911. Email: sales@ormandygroup.com

www.ormandygroup.com